

Indoor High Resolution Colour CCD Dome Camera

SD13H



Key Features

- 1/3" SONY ExView HAD CCD Image Sensor
- SONY Digital Signal Processing (DSP) Chip set
- High Resolution 520 TV Lines
- 3.6mm Board Lens
- Stylish Compact Housing
- 0.1 Low Lux
- Made in Taiwan

Specifications

Brand	TANDER
Model	SD13H
Image Pick-up Devive	1/3" SONY ExView HAD CCD
Signal System	PAL
Total /Effective Pixels	752(H)x 582(V)
Scanning System	2 : 1 Interlace
Lens	3.6 mm board lens
Scanning Frequency	50Hz(VD)
Resolution	520 TV lines
Video Output	CVBS : 1.0Vp-p / 75Ω
S / N Ratio	More than 48dB
Min. Illumination	0.1 Lux
Sync. System	Internal
Signal Process	Digital Signal Processing
Back Light Compensation	Built-in
Gain Control	Auto
Electronic Shutter Speed	Auto / (1/50 ~ 1/100,000)
White Balance	Auto
Power Source	12V DC ±10%
Power Consumption	90 mA
Operating Temperature	-10°C ~ +65°C
Operating Humidity	0% ~ 80% RH
Dimension	106(ø) x 60(H)mm
Weight	135g
Country Of Origin	Taiwan

Dimensions

(UNIT: mm)

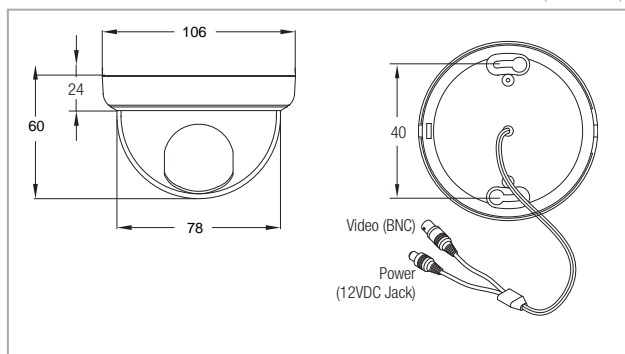

Connection Diagram

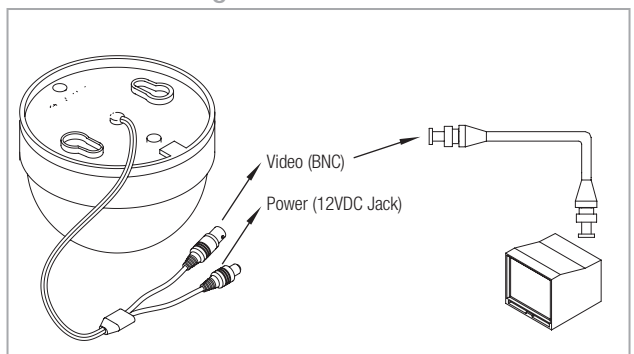

TANDER®