

General Purpose Day & Night IR Dome Camera

DIR1524H



Key Features

- 1/3" SONY Exview HAD CCD
- SONY Digital Signal Processing (DSP) Chip set
- 3.6 mm board lens, High Resolution 520 TVL
- 24 nos. of 850nm IR LED, 15 meters coverage
- Build in CDS Delay Chip set for IR LED Sensor
- Made in Taiwan

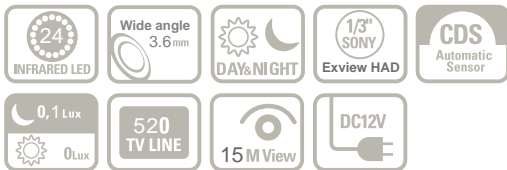

Specifications

Brand	TANDER
Model	DIR1524H
Image Pick-up Devise	1/3" Sony ExView HAD CCD
Signal System	PAL
Total /Effective Pixels	752(H)x 582(V) 320K
Scanning System	2 : 1 Interlace
Lens	3.6mm Board Lens
Scanning Frequency	50Hz(VD), 15.625Hz(H), 50Hz(V)
Resolution	520 TV lines
Video Output	CVBS : 1.0Vp-p / 75 composite BNC Connector
S / N Ratio	More than 48dB (AGC Off)
IR LED	24 nos. of 850nm IR LED, 15 meters coverage
Min. Illumination	0.1 Lux (F : 1.2) , 0 Lux (IR LED On)
Sync. System	Internal
Signal Process	Digital Signal Processing
Back Light Compensation	Built-in
Gain Control	Auto
Electronic Shutter Speed	Auto / (1/50 ~ 1/100,000)
White Balance	Auto tracking 2500K to 9500K
Housing	Stylish Plastic Housing
Power Source	12V DC \pm 0%
Power Consumption	110 mA (IR LED off) , 400 mA (IR LED on)
Operating Temperature	-10 C ~ 45 C
Operating Humidity	0% ~ 80% RH
Dimension	93mm(O) x 76mm(D)
Weight	39g
Country Of Origin	Taiwan

Dimensions

(UNIT: mm)

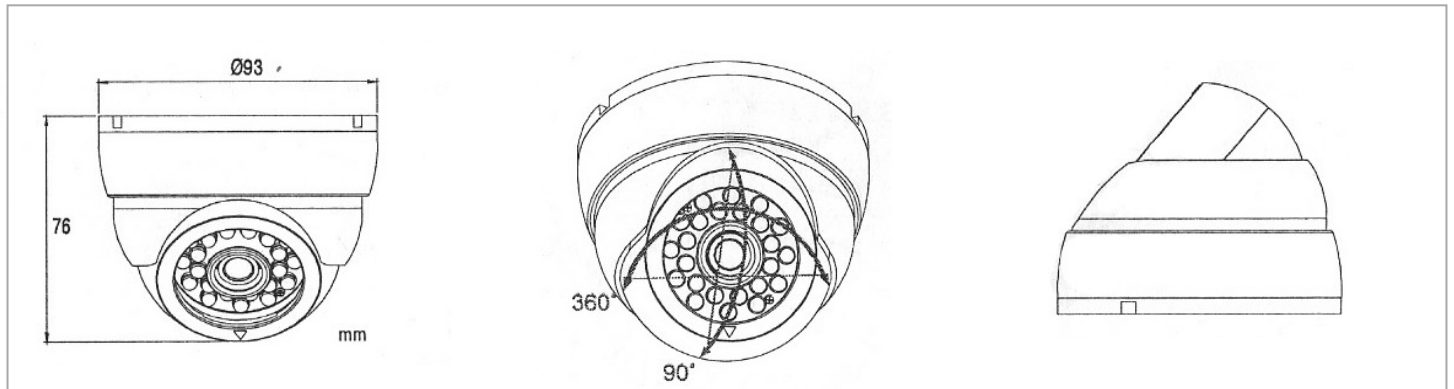

TANDER[®]